

LOCKING DROPBOLT



- G** Robust – Strongly constructed and available in electro-galvanised steel with the option of a stainless steel bolt.
- G** Easy to fit – Needs just two 15mm holes in the gate and fixed with the expanding fasteners provided.
- G** Adaptable – Fits left and right hand gates
- G** Innovative and secure – Once the dropbolt is lowered and rotated, closing the second gate prevents the dropbolt being unlocked.



PRODUCT DETAILS

Product code:	Description:
LDB	Locking dropbolt, electrogalvanised + powdercoated steel
LDBSS	Locking dropbolt, electrogalvanised + powdercoated steel with stainless steel bolt

Dropbolt diameter 19mm
Dropbolt movement 140mm



INSTALLATION

- Drill 2x 15mm holes, 20mm from the leading edge of the gate at 140mm centres, and fix the dropbolt guide to the gate with the 2 expanding fasteners supplied.
- Fit the small location pin into the most suitable of the 3 location holes with the smaller screw provided.
- Slide the dropbolt into the dropbolt guide, with the location pin facing into the back corner and then twist into position.
- Fix the lift plate to the dropbolt in the correct position with the screw provided.

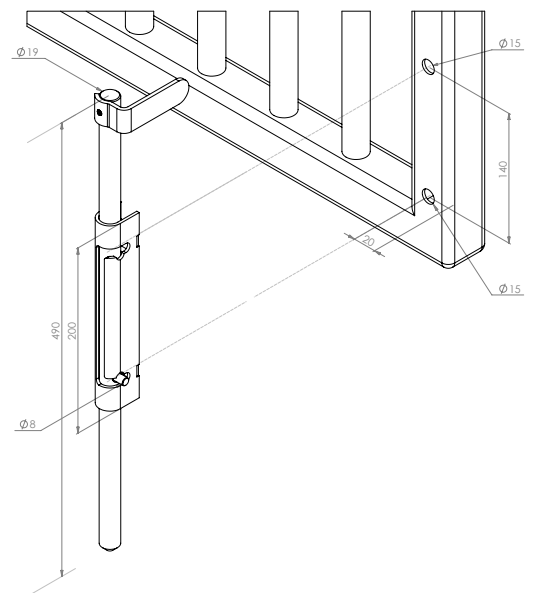

MAINTENANCE

Lubricate sliding parts when needed.



VISIT GATEMASTERLOCKS.COM FOR MORE INFORMATION

