

DOUBLE THROW DEADLOCK



G This weld-in lock is a durable and good value solution wherever you need to fit a lock to a welded fabrication.

G The double throw deadbolt moves 15/16" and the lockcase is made of 7/64" (2.5mm) mild steel.

G Supplied with double sided 5 pin eurocylinder - keyed alike and thumbturn eurocylinders available.

G This lock is available in a Fire Brigade version for use with a FB1 and FB2 key.



PRODUCT DETAILS

Product code:	Description:
GD25	1" case width
GD30	1-1/4" case width
GD40	1-1/2" case width
GD50	2" case width
GD60	2-3/8" case width

Deadbolt:	Moves 15/16".
Material:	Mild steel.
Includes:	5 pin eurocylinder and weld on keep plate.
Extra:	Fire Brigade version FB1 and FB2 key available.



INSTALLATION

1. Weld the lockcase to the gate and galvanise or paint as part of the gate.
2. Fit the lock and eurocylinder into the lockcase and secure with countersunk screw.
3. **MAINTENANCE** Annually - remove lock from lockcase and lightly oil all moving parts.

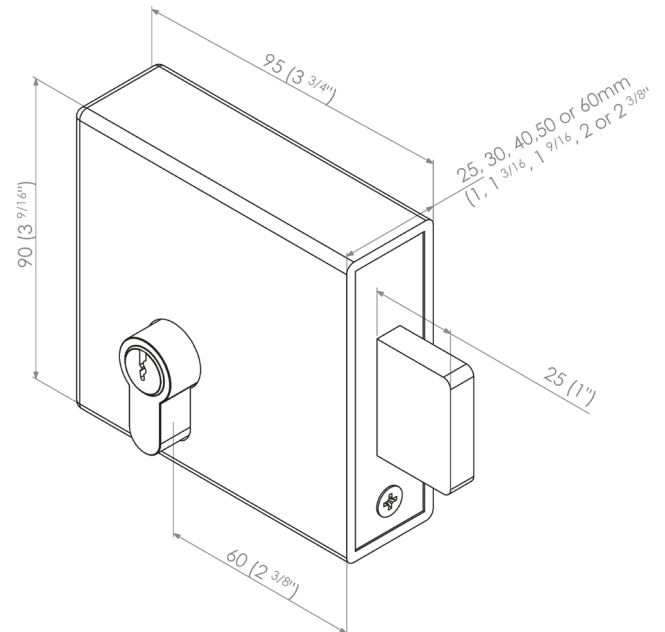

VISIT GATEMASTERLOCKS.COM FOR MORE INFORMATION

