

GATE CLOSING GAS STRUT



SPECIFICATION SHEET

GSB

- G** Top quality gate closing strut, ideal for closing gates up to 80kg (175lb).
- G** Using the unique adjustable brackets the force this closer exerts can be altered as required.
- G** No need to release gas, simply move the strut along the slots in the brackets to adjust the force exerted. The force can be increased again by moving the strut further than the gate hinge.
- G** The adjustable brackets also make the installation easy as there is no need to compress the spring when fitting it to the gate.

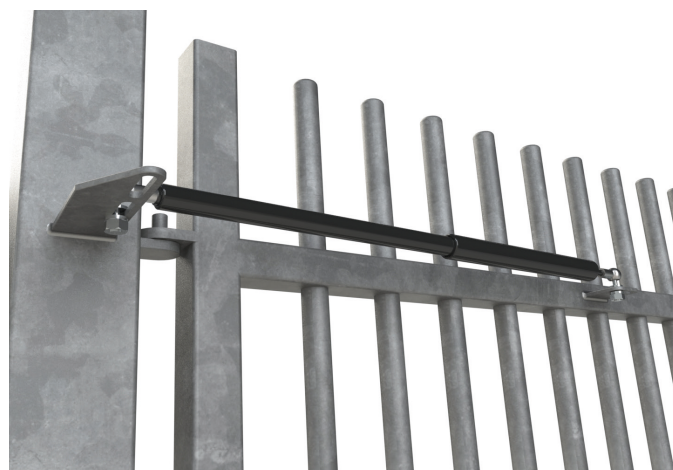

PRODUCT DETAILS

Product code:	Description:
GSB	Weld on gate closing strut
GSBW	Screw fix gate closing strut

Max gate weight:	80kg (175lb)
Max gate size:	2500mm (8ft 2.43") high x 1200mm (3ft 11") wide
End fittings:	M10 elbow joints
	Fitted with steel rod protection tube.
Finish:	Black finish
Center to center:	792mm (9-3/16")
Stroke length:	240mm (9-29/64")
Force:	300N



INSTALLATION

- Fix the brackets supplied in position relative to the center of the hinge as shown. **WARNING!** Do not weld the brackets with closer fitted, this could damage the seals.
- Close the gate and secure the strut to the slotted bracket and the long bracket using the shakeproof washers and nuts provided. Washer positions are as shown. To increase or decrease the force exerted on the gate, reposition the strut on the long bracket as required.
- IMPORTANT:** if the gate can be opened more than 90° there is potential for the strut to be damaged. We recommend fitting a stop to prevent this.

MAINTENANCE: The piston rod is protected by a steel cover tube. The piston rod should not be lubricated or damaged in any way, as this will reduce the life of the seals. Periodically lubricate the ball joints with a light oil and clean the surface of the gas strut with a damp cloth.

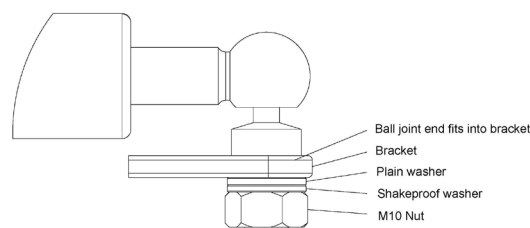
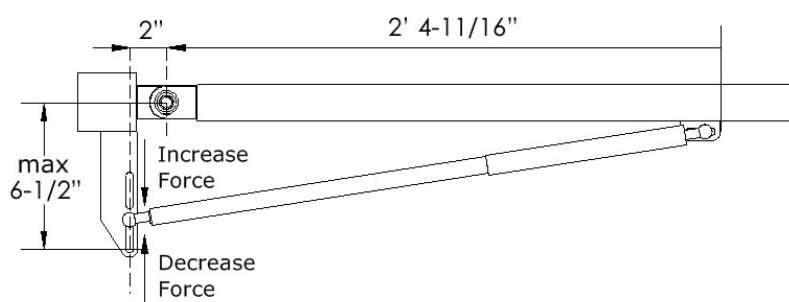

GATEMASTER

VISIT GATEMASTERLOCKS.COM FOR MORE INFORMATION

