

# SELECT PRO WELD IN LATCH DEADLOCK



- G Stainless steel latchbolt which springs 13mm (1/2") into the gate post and then moves 30mm (1-1/8") when the key is turned to deadlock.
- G Latchbolt is adjustable in length for precise fitting on site. Easy to rotate for Left handed and Right handed gates.
- G Handles ordered separately.
- G Supplied with bolt guide plate and gate post strike plate.



## PRODUCT DETAILS

Product code:	Description:
SWLD1630	For 30mm (1-1/8") wide gate frames
SWLD1640	For 40mm (1-5/8") wide gate frames
SWLD1650	For 50mm (2") wide gate frames
SWLD1660	For 60mm (2-3/8") wide gate frames

Style of handle:	Description:
TDH	Traditional handle set
OK	Octagonal handle set
AH	Black lever handle set

**Bolts:** Adjustable, latchbolt springs 13mm (1/2") and deadbolt moves 30mm (1-1/8").



Perfect for both left and right handed gates.

## INSTALLATION

1. Disassemble the lock by removing the 3 screws from the face plate of the lock, remove the face plate, and then remove the euro cylinder (twist the key 15 degrees clockwise or anti-clockwise to release). The insides of the lock will then slide out.
2. Weld the lockcase to the gate and galvanise or paint as part of the gate.
3. Fit the lock and eurocylinder into the lockcase and secure with screws.
4. Weld the strike plate to the gate post and bend to provide a ramp for the latch to ride up.
5. **MAINTENANCE** Every two months, lubricate the latchbolt with light oil. Annually, dismantle lock and spray the mechanism inside with light oil.

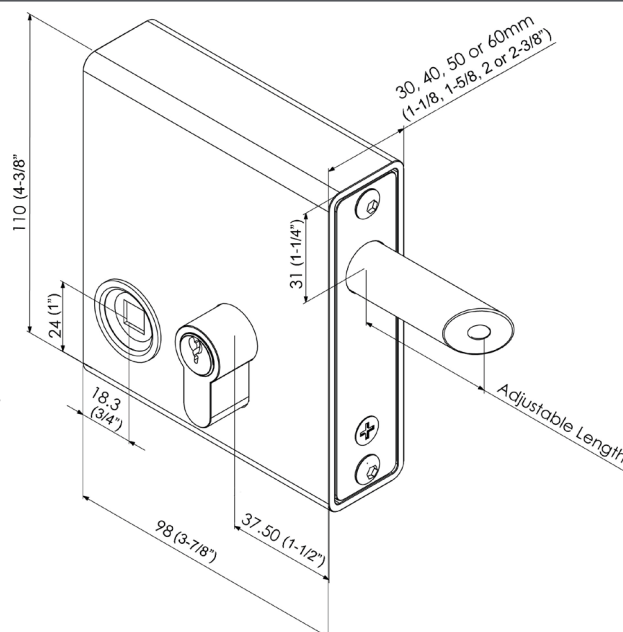

VISIT [GATEMASTERLOCKS.COM](http://GATEMASTERLOCKS.COM) FOR MORE INFORMATION

