

SUPERLOCK DIGITAL LEVER HANDLE DOUBLE SIDED



SPECIFICATION
SHEET

BDGL

- G** Lever Handles - easy to operate handles, particularly for those with mobility issues who find gripping and turning difficult.
- G** Easy to fit - Slim 70mm (2-3/4") wide lock case along with adjustable and removable latchbolt ensure easy fitting to gates.
- G** Durable - The outside handle moves freely to avoid the inner mechanisms being damaged.
- G** Secure - The latchbolt moves 15mm (5/8") ensuring the bolt enters deep into the gatepost. This lock is also fitted with an anti-climb handle to prevent intruders using the handle as a foot hold to climb the gate.
- G** Non handed - Suits both left and right hand gates.
- G** This lock has keypads on both sides.

PRODUCT DETAILS

Product code:	Description:
BDGL1030	To fit 10-30mm (1/2" - 1-1/4") gate frames
BDGL4060	To fit 40-60mm (1-1/2" - 2-1/4") gate frames



INSTALLATION

1. Drill 2 x 9mm (3/8") holes at 140mm (5 1/2") centres for fixing bolts provided.
2. Drill 18mm (3/4") clearance hole for the latchbolt at 60mm (2 3/8") centres up from the bottom fixing hole.
3. Fix the handles to the square spindles so that the handles are facing away from the latchbolt and secure using the hex key supplied.
4. Hold the lock against the back of the box section and screw on the latchbolt through the larger hole.
5. Lock the latchbolt with the hex key supplied by inserting the hex key into the end of the latchbolt.
6. Fix lock in place using the stainless steel bolt support plate and the countersunk screws provided. Ensure the latchbolt moves freely.
7. Fix strike plate by either welding or screw fixing onto the gate post.
8. **MAINTENANCE** Every 6 months, lubricate the latchbolt with light oil. Annually, dismantle the lock and spray mechanism with light oil.

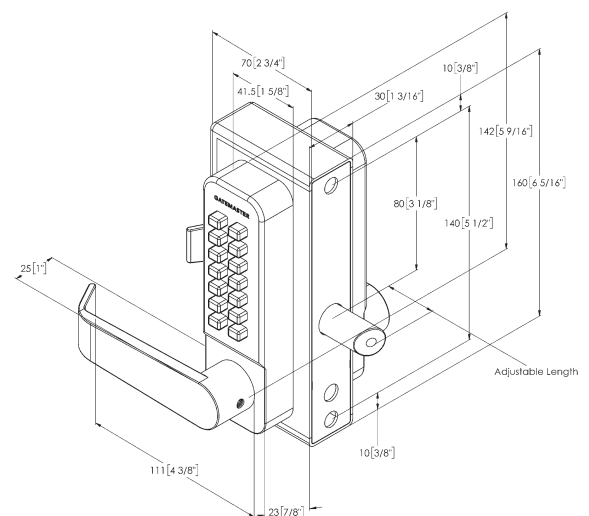

 **GATEMASTER**

VISIT GATEMASTERLOCKS.COM FOR MORE INFORMATION

SUPERLOCK DIGITAL LEVER HANDLE DOUBLE SIDED



SPECIFICATION
SHEET

BDGL

LOCK CODE:

C _____

TO CHANGE THE CODE

1. Check the original code is working on the keypad.
2. Remove the keypad off the lock. To do this, slide the keypads and lock insides out of the case spine and unscrew the two screws fixing the keypad to the panel.
3. Turn the keypad over and remove the 4 screws.
4. Lift off the covering panel carefully as there are 10 springs attached to this panel. Note that the red tumblers relate to the code shown above. Also note that the C tumbler is uncoloured and should not be removed.
5. To change the code hold the keypad with the code buttons down and depress & hold the C button (if this is not done you may damage some of the internal components). Reposition the tumblers to the new code (red tumblers are coded and blue tumblers are uncoded). Ensure that the square cut-out on each tumbler is facing the outside of the lock body, also ensure that the coloured mark is facing upwards. If any one tumbler is upside down or the wrong way round the lock will not work and if forced will break the internal components. The code must always start with a 'C'.

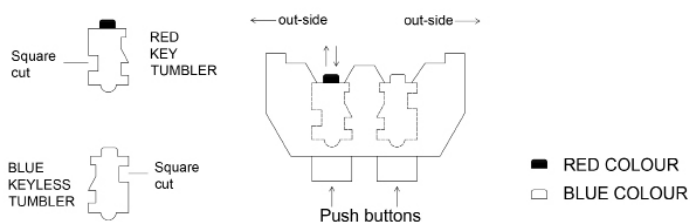

6. Replace the covering panel and tighten the 2 screws
7. The code is now changed, check to see that it is working correctly and make a note of the code for future reference. Once satisfied that the lock is working correctly refit keypads to the panel using the 2 screws and reassemble the lock.

MAINTENANCE

6 monthly:

1. Remove keypads from the lock.
2. Spray the inside of the lock thoroughly with WD40 or equivalent, through the tumbler holes at the back of the lock.
3. Spray all the fixing accessories and the latch with WD40 or equivalent.
4. Push each of the buttons and rotate the knob several times to make sure the lock is working smoothly.

 **GATEMASTER**

VISIT GATEMASTERLOCKS.COM FOR MORE INFORMATION

